

Batch vacuum processing plants type zoatec® BG:

Ingenious modularity gives
flexibility wherever it is needed

BATCH PLANTS



For mixing,
dispersing and
homogenising
liquid and
semi-solid products



For liquid processes

AZO.
LIQUIDS



Modular design

Batch vacuum processing plants type zoatec® BG: mixing, dispersing and homogenising

Fresh power for your liquid processes

The modular vacuum processing plants type zoatec® BG structured in assembly groups can be used everywhere that dry powders and liquids, or liquids and liquids, have to be mixed, dispersed and emulsified. As a result, they cover a wide product spectrum for liquid to paste-like applications in the areas of pharmaceuticals, food,

cosmetics and chemicals. Also, they are characterized in particular by short batch times. AZO LIQUIDS processing plants stand out from all conventional plants with their ingenious design. Complete processing plants are assembled from standardized modules. The modules are independent from the process parameters, and can

be adapted to your requirements with great flexibility.

The entire series is designed according to similar geometrical principles, thereby making scale-up considerations much more precise. As a result, it is possible to concentrate on the actual process parameters in the

planning phase, in order to make realistic predictions. Furthermore, the design offers major advantages in the areas of production, cleaning and maintenance.

Application areas for liquid and semi-solid products

• Food



• Pharmaceuticals



• Chemicals



• Cosmetics





Top: Process module, left: Supply module

domed agitator with dissolver

standard agitator 80° with flow breaker

Innovative design

Separation between process and supply module

Advantages of this design:

- Separation between production and technical areas
- System can be installed even under unfavorable room conditions

- Easy realization of extensions and special guidelines (ATEX, sterile, hygiene, etc.)
- When load cells are used on the process module, disturbance source from the supply module are avoided

Innovative agitator and mixer

Agitator combination options:

- Combinations from one fixed to two mobile flow breaker(s) are possible
- Other mixing elements can be integrated (dissolver, jet stream homogenizer, etc.)

Advantages of this design:

- Can be optimally adapted to your product requirements
- Improved heat exchange
- Optimized discharge of residual quantities
- Shorter CIP process due to more turbulences
- Shortened batch times

Machine frame in comb design

Advantages of this design:

- Process and supply modules can be installed separately
- All components on the process vessel are easily accessible (process handling, cleaning, and maintenance)

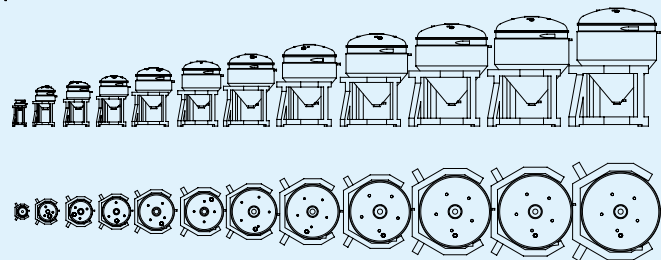

- Setup on only 4 machine legs (4x load cells with high evaluation accuracy)
- Frame always has the same design (scale-up ability)
- Frame accepts any vessel design without rebuild (conical 80°, conical 130°, domed, etc.)



The modified bottom design in the same series makes it possible to achieve variable batch volumes of approx. 60%, thereby adjusting to any customer requirement or situation.

Example of a plant with 130° conical vessel BG400/600K



Easily accessible homogeniser

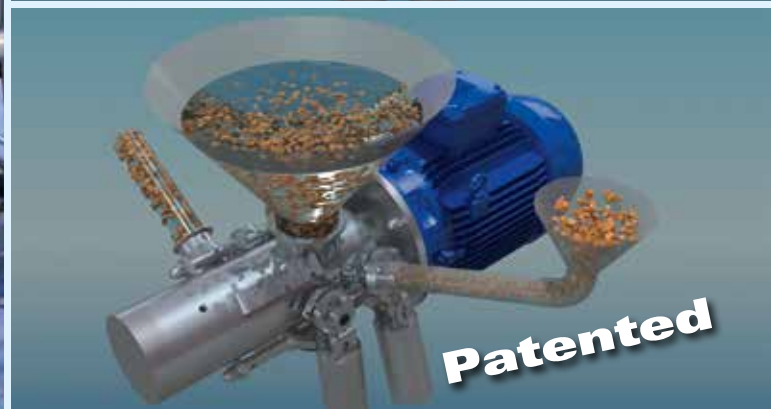

Top: Dispersing mode, down: Pump mode

Modular is better!

AZO LIQUIDS Homogeniser

Advantages of this design:

- Small droplet size with optimum distribution due to a constant product feeding to the tools
- Fast incorporation of large powder quantities and of reactive products due to high pump and shear rate
- Homogeniser transports away from the mechanical seal, therefore less stress and wear, longer service life

- Fast product deaeration
- Tools and mechanical seal can be easily inspected and demounted in front
- GMP design, CIP, SIP, DIP and ATEX-capable
- Homogeniser can be used as CIP pump due to high pump rate

AZO LIQUIDS Pump mode

Advantages of pump mode:

- Non-destructive incorporation of lumpy goods without mounting an additional pump with pipework
- Faster product discharges with a large batch volume and when working with shear sensitive products
- Improved incorporation of large powder quantities

Sample applications:

- Food: mixing in vegetable and fruit pieces
- Cosmetics: mixing in abrasive particles and pigments
- Pharmaceuticals: for products that are shear sensitive such as active ingredients or pigments

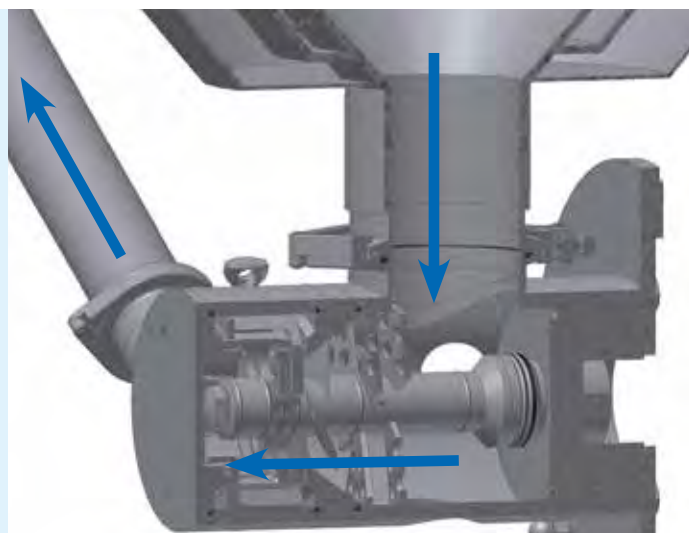

Homogeniser with throughflow direction opposite to the mechanical seal

Flow rate of homogeniser

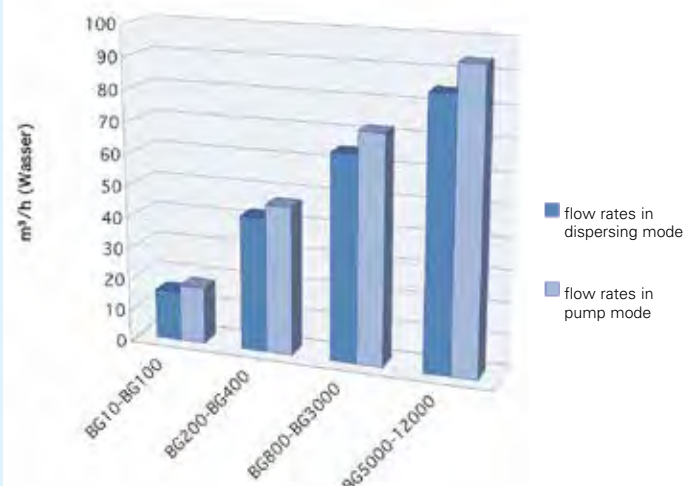

Comparison between flow rates in dispersing and pump modes: The flow rates are optimally adapted to the holding time in the shearing zone. (approximate values)



Your requirements – our solutions:

- Flexibly applicable system
- Short installation and startup times
- Ease of compliance from special guidelines
- Reliable batch times
Calculation by optimized scale-up process
- Constant product quality in each batch
- Easy to clean and maintain
- Low operating costs
- Straightforward operation

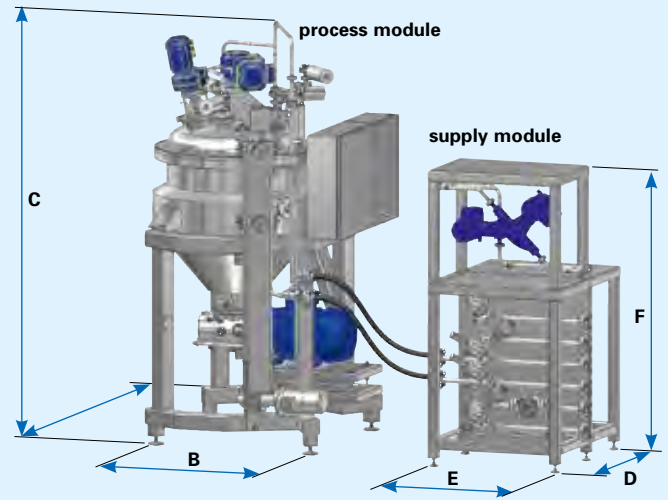

Technical data in detail

Size zoatec® BG: 10, 100, 200, 400, 500, 800, 1.200, 2.000, 3.000, 5.000, 7.500, 9.500, 12.000

Sizes:	Minimum start volume liter	Maximum useable volume liter	Process module			Weight kg	Supply module			Weight kg
			A mm	B mm	C mm		D mm	E mm	F mm	
BG10	4	10	800	900	1.500	350	600	600	1.600	150
BG100	40	100	1.200	1.200	1.850	600	900	800	1.600	200
BG200	80	200	1.400	1.400	2.350	750	1.050	800	1.800	250
BG400	150	400	1.600	1.600	2.600	1.000	1.050	800	1.800	350
BG500	170	500	1.700	1.700	2.700	1.200	1.050	800	1.800	350
BG800	340	800	2.000	2.000	3.000	1.500	1.250	1.000	2.000 – 2.200	500
BG1200	430	1.200	2.200	2.200	3.200	2.300	1.250	1.000	2.000 – 2.200	700
BG2000	760	2.000	2.400	2.400	3.600	3.000	1.500	1.000	2.200 – 2.500	900
BG3000	1.240	3.000	2.700	2.700	3.900	4.500	1.500	1.000	2.200 – 2.500	1.500
BG5000	1.890	5.000	3.200	3.200	4.300	11.000	1.500	1.000	2.200 – 2.500	3.500

Subject to technical modifications.
Larger plants and dimensions for vessel versions with conical 130° and domed bottom available on request.

Process control

The zoamatic control is a system that can be extended, so that it can be used for controlling anything from individual basic functions through to fully automatic recipe mode or even the complete batch documentation of all customer requirements.

The following variants are possible:

- **zoamatic smart** – Basic HMI solution for a specified range of functions
- **zoamatic professional** – Modular concept with extension options based on the SCADA system
- **zoamatic remote** – complete PLC control with interface for connecting to an external system
- **zoamatic lib** – Integration into another system



Control terminal with process visualization

Our range of services

- Engineering for complete plants and complete AZO group projects
(AZO SOLIDS – AZO LIQUIDS – AZO CONROLS)
- Plant construction to customers' requirements (e.g. continuous plants and late stage mixing)
- Sterile configurations and ATEX applications
- CPC (Customer Process Center)
including tests with customer products, product analyses, scale-up calculations
- Project management
- Consulting, process analysis and optimization
- Qualification and validation
- Re-qualification of existing plants
- IQ / OQ documentation and implementation
- Software systems (new installation and modernization)
- Startups and training
- Conversion, maintenance and repair
- Aftersales / support and service / mechanical and electrical spare parts



AZO LIQUIDS office building



AZO LIQUIDS production



AZO LIQUIDS GmbH

Gottlieb-Daimler-Straße 4
D-79395 Neuenburg am Rhein
Tel.: +49 (0)7631 9739-0
Fax: +49 (0)7631 9739-301
azo-liquids@azo.com
www.azo-liquids.de